

A CONTROL SCHEME OF AN INTERLEAVED FLY BACK INVERTER FOR PHOTOVOLTAIC APPLICATION TO ACHIEVE HIGH EFFICIENCY

DHANRAJ DAPHALE

Department of Electrical Engineering, Tulshiram Gaikwad Patil College of Engineering and Technology, Nagpur, India
 * daphale3d@gmail.com

DR. HARIKUMAR NAIDU

H.O.D Department of Electrical Engineering
 Tulsiramji Gaikwad Patil College of Engineering and Technology
 Mohagaon, Wardha Road, Nagpur, Maharashtra, India

ABSTRACT

The Study shows that how Interleaved fly back inverter is useful in photovoltaic application in order to achieve higher efficiency for improving the performance. The fly back topology is basically operated in Discontinuous conduction mode. The main aim of this study to develop the inverter with low cost which will help in order to achieve the higher efficiency. This reduction of cost is achieved by using flyback inverter topology. The controller performance and inverter design checked by using the simulation result for given particular specification. With help of experimental result it is possible to achieve the efficiency at 86% at full load and power factor which is very close to the unity.

INTRODUCTION

As we know that solar energy is renewable energy sources which considered as having the greater application in coming future. Energy market is trying to focus on use solar energy for improving the performance of system and achieve the higher efficiency. This is the main reason behind the research & development in solar technology. One of the most important disadvantages is higher initial cost which brings some limitation for its use in the world. But in order to achieve the high efficiency and better performance of system, cost plays the vital role. So this cost reduction is achieved by using the flyback inverter topology. This topology having the lower cost as compared to the other topologies because it uses fewer components as compared to the other scheme. The energy storage inductor is combined with the transformer which is separate in other topologies. Transformer performs the function of transfer of energy while inductor performs the function of storage of energy. The reduction of cost is possible by using the combination of this two equipment. The transformer used in this scheme having the special name called as the “Flyback transformer” in order to distinguish it from other transformer. The important use of flyback topology is limited below 200 W. Nevertheless, if advanced design techniques are employed, the flyback converter can be used in high power applications as well. Whatever the power of scheme is there which shared equally by each unit which is another advantage of this technique.

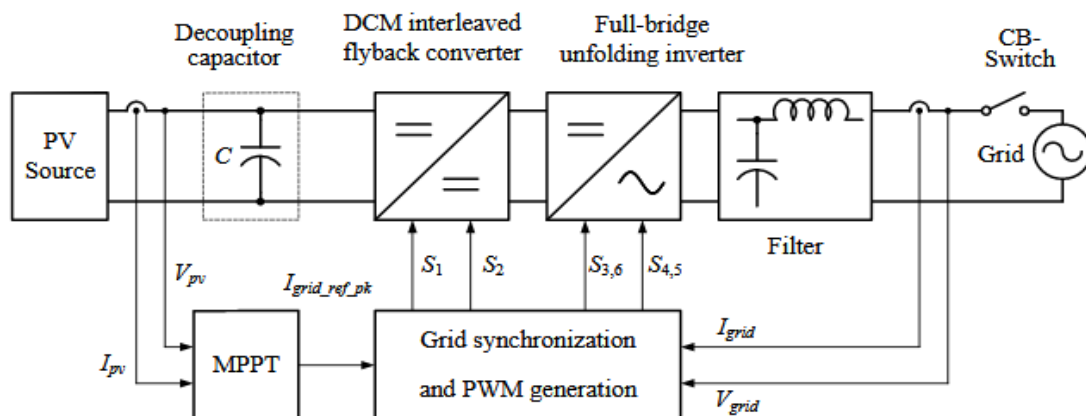

Figure. No 1: Block diagram of grid-tied fly back based PV inverter system

Fig.1 shows the block diagram of the proposed flyback based inverter system in which the PV source is connected to the interleaved flyback converter. Grid synchronisation is also shown in to the block diagram. Fig.2 shows the topology of two-cell interleaved flyback PV inverter system, for illustrative purposes. The actual and optimum cell number is determined in the design section of the paper.

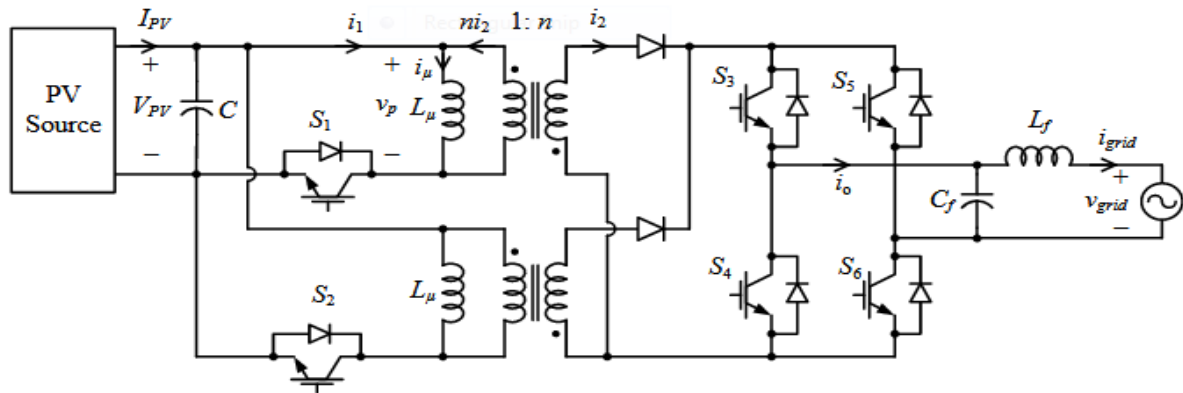

Figure no.2: Circuit of flyback PV inverter power stage based on two interleaved cells

With the reference of Fig.2 PV source is connected to the converter with the help of decoupling capacitor. Switch used in this scheme is nothing but IGBT. Low pass filter is also used for the interconnection with the grid. When the IGBT is turned on, a current flows from the PV source into the magnetizing inductance of the flyback transformer and the energy is stored as magnetic field; no current flows to the output due to the position of the secondary side diode. During the on time of the IGBT, the energy to the output is supplied by the capacitor and the inductor placed at the output stage. When the IGBT is turned off, the energy stored in the magnetizing inductance is transferred into the grid through the transformer windings. Low pass filter is helpful for supplying the current to grid. It is also helpful in removing the high frequency harmonics of the pulsed current waveform. The decoupling capacitor placed at the flyback converter is designed or placed in such a way that both the low and the high frequency ac components are easily bypassed and only the average (dc) component of the current is allowed to be delivered by the PV source.

CONVERTER ANALYSIS

While doing the converter analysis we basically consider the two cases. In first case we analyse the system when switch is turned ON. In second case we analyse it when switch is turned OFF. The typical waveform when switch is turned ON and OFF is shown below. When the switch is turned on in Fig. 2, the PV voltage is applied to the flyback transformer primary winding. If it is assumed that the PV voltage is constant and current starts from zero initial value (because of the DCM operation).

When the switch is turned off, the flyback transformer primary voltage becomes negative of the grid voltage after divided by the turn ratio. At the end of the switch off time, the magnetizing current decreases from its peak value to zero. Fig.3 shows converter voltage, flyback transformer primary voltage V_p and magnetising current I_μ over a one switching period. With the help of switch IGBT it is possible to achieve the high efficiency.

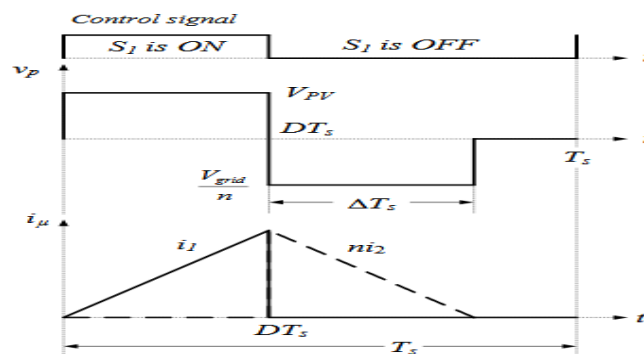

Figure no.3: Control signal, flyback transformer primary voltage V_p and magnetization current

CONVERTER DESIGN

Design specification related to the converter design is given in following table:

Table 1: Design Specification

Design Parameters	Specification
PV model	65 W
Open circuit voltage and short circuit current	21.6 V, 3.99 A
Grid characteristics	Single-phase nominal 220 V and 50 Hz , 185V –240 V rms voltage range 45.5 Hz –54.5 Hz frequency range
Voltage and current at maximum power	17.6 V, 3.69 A

DESIGN OF PV INVERTER STAGE

The decoupling capacitor plays vital role and it is very important part of circuit. The value of capacitor is mainly decided with the help of ripples. A small ripples means large value of capacitance. So there is some proper relation between ripples and value of capacitor that we are going to choose. The value of decoupling capacitor is nearly about 9400 μF . Here in this operation we are giving the preference to use switch as IGBT because of their ruggedness under high current and voltage stress. At the last stage, the converter employs an IGBT bridge operating at the grid frequency. This bridge is responsible for converting the dc secondary currents into ac, and therefore provides an interface to the grid through a low-pass filter. The filter is responsible for removing the switching frequency components of the sinusoidally modulated currents. The switching frequency of each flyback cell is 25 kHz. Therefore, the ripple frequency of current waveform at the output of the inverter is 75 kHz due to the interleaving. So, the corner frequency of the low-pass filter is selected as 7.5 kHz.

DESIGN OF CONTROL SYSTEM

Design of control system also plays important part in the flyback inverter topology. Control systems have to perform the different function in within a small time. Its first function is , it should regulate a proper dc current and voltage at the PV interface for maximum energy harvesting. Its second function is it must provide control to convert the dc current that comes from the panels and continuously regulated for the MPPT purpose into ac current at the grid interface for power injection. In addition, this ac current should be synchronized with the grid frequency, should have low harmonic distortion and a power factor close to unity. The typical control system model using Simulink is shown below:

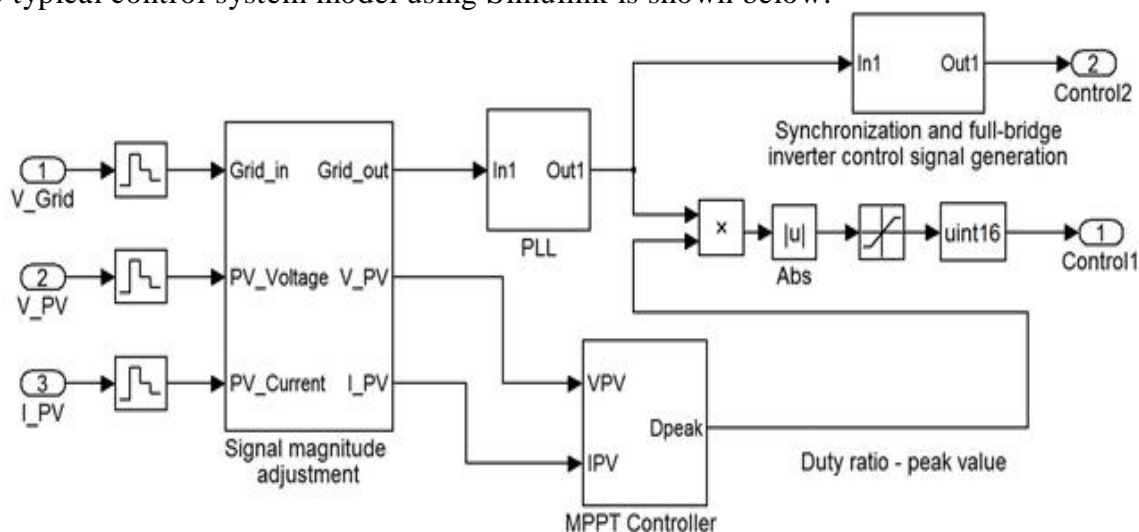

Figure no.4: Simulink Model of control system

CONCLUSION

The main objective of reduction in cost is satisfied using this topology which helps in commercialization of solar technology. The design of converter is simple and it is compact in nature. Building the inverter system based on the flyback converter topology offers the lowest cost since it requires the least number of components, operating in the discontinuous current mode enables very simple and always stable control system, and finally three-cell interleaved operation allows compact flyback transformer construction. The efficiency of system is going to be increased as compared to the previous system. Furthermore, the performance of the proposed system is comparable to the commercial isolated grid-connected PV inverters in the market, but it may have some cost advantage due to its topological benefit.

REFERENCES

- I. Hu H., Harb S., Fang X., Zhang D., Zhang Q., Shen Z. J., and Batarseh I.: A Three-port Flyback for PV Microinverter Applications With Power Pulsation Decoupling Capability, *IEEE Transactions on Power Electronics*, vol. 27, no. 9, pp. 3953 - 3964, September 2012
- II. Nanakos A. C., Tatakis E. C., and Papanikolaou N. P.: A Weighted-Efficiency-Oriented Design Methodology of Flyback Inverter for AC Photovoltaic Modules, *IEEE Transactions on Power Electronics*, vol. 27, no. 7, pp. 3221-3233, July 2012.
- III. Kim Y.H., Kim J.G., Ji Y.H., Won C.Y., and Lee T. W.: Flyback inverter using voltage sensorless MPPT for AC module systems, in 2010 International Power Electronics Conference (IPEC), 2010, pp. 948-953.
- IV. Shimizu T., Wada K., and Nakamura N.: Flyback-type single-phase utility interactive inverter with power pulsation decoupling on the DC input for an AC photovoltaic module system, *IEEE Transactions on Power Electronics*, vol.21, no.5, pp.1264-1272, Sept. 2006
- V. Tamyurek B. and Torrey D. A.: A three-phase unity power factor single-stage ac-dc converter based on an interleaved flyback topology, *IEEE Trans. Power Electron.*, vol. 26, no. 1, pp. 308–318, Jan. 2011
- VI. Overall Efficiency of Photovoltaic Inverters, EN 50530.
- VII. Esram T. and Chapman P. L.: Comparison of photovoltaic array maximum power point tracking techniques, *IEEE Trans. Energy Conversion*, vol. 22, no. 2, pp. 439–449, June 2007
- VIII. Solar Energy, (2013, June 15). Available: http://www.conserve-energy-future.com/Solar_Energy.php.