

## DESIGN AND ANALYSIS OF IMPACT OF JET ON VANES

Niranjan Aatkare

Department of Mechanical Engineering

Dr. D. Y. Patil College of Engineering and Innovation, Varale, Talegaon, Pune  
aatkarens333@gmail.com

Suyog Kulkarni

Department of Mechanical Engineering

Dr. D. Y. Patil College of Engineering and Innovation, Varale, Talegaon, Pune

Akshay Kodlangare

Department of Mechanical Engineering

Dr. D. Y. Patil College of Engineering and Innovation, Varale, Talegaon, Pune

Saurabh Borkar

Department of Mechanical Engineering

Hetal Parmar

Asst. Prof. Department of Mechanical Engineering

Dr. D. Y. Patil College of Engineering and Innovation, Varale, Talegaon, Pune

**ABSTRACT**—Water is used to generate the force and this forced water is impacted on the surface which is measured and compared to change in momentum of the jet. In the experiment water nozzle, a set of target plates, a spring scale connected to the balance beam, flow meter and pipes for recirculation of water have been used. This paper focuses on determination of experimental, theoretical force and percentage of error.

**Keyword**-Component Reaction force, Target vanes, Weight plate, Flow rate, Experimental and theoretical force.

### I. INTRODUCTION

When the jet of water strikes on the obstruction like a flat inclined, hemispherical plate vanes in its path, then the jet exerts the force on the obstruction is known as Impact of jet.[1] Newton second law of motion states that “the applied force is equal to rate of change in momentum.” [2] In momentum equation the algebraic sum of external forces applied to control volume of fluid in any direction equal to the rate of change of momentum in that direction, in equation form,  $p=mv$ , where  $p$  is momentum,  $m$  is mass in kg and  $v$  is velocity of jet in m/s. momentum equation is vector quantity, this means it has both magnitude and direction. [3]

### II. EASE OF USE

The flow jets are broadly encountered in nature and convert wide range of application including gas and water turbine, aircraft and solid rocket motors, boundary layer separation control over a wing, film cooling on turbine blades etc.

### III. LITERATURE REVIEW

Jain et al.[1] verified the momentum equation by Impact of jet apparatus on flat plate. In this research paper they discussed that the nozzle diameter was not affect on force exerted on vanes and discharge .In this research paper he investigate about the flat plate vane and verify the momentum equation.

Shinde et al [2] Titled “Determination of force on flat and inclined plates using weighting pan in test rig of impact of jet”. They investigate about how to determine force on flat and inclined plate by using digital weighting pan in test rig of impact of jet. They concluded in this paper that as the discharge increase the value of force exerted also increase. Hossain et al [3] studied the measurement of flow rate and impact force on different vanes through impact of jet. They investigated the measurement of flow rate and impact force using different vanes and impact of jet of pressurized water .The main object of the research paper is to focus on the experimental analysis of the impact of jet on different target plates.

Yusuf koc et al. [4] titled “An experimental study of mechanical effect in cleaning process. Investigation was carried out on the cleaning process to the impingement of jet, the main parameter that influence the cleaning performance are water temperature, chemicals, cleaning time and impact on the surfaces. Cleaning is the process of using water to remove soil, rust stains or other deposits from surface.

Rathore et al [5] studied the role of vane angle and its shape on jet mixing of a subsonic coaxial jet. Investigation was carried out on the noise emission control from the jet engine. It is one of the biggest emerging trends in the industry and the defense.

#### IV. PROBLEM STATEMENT

1. To calculate experiment and theoretical forces and find out percentage of error.
2. To reduce the discharge for reduce the error in the force exerted on the vanes.

#### V. EXPERIMENTAL SET UP

Impact of jet is a closed circuit. It consists of nozzle different types of vanes, pump pipes for water circulation sump tank measuring tank.

The set up primarily consist of a vanes and nozzle through which jet emerges in vertical direction to which on vanes attached to balancing weight.

The vanes and the nozzle setup were placed in the transparent acrylic cylinder. The scale is placed above the acrylic cylinder and helps to determine the original position of plates (vanes) to before the impact of water jet on the plates.

Sump tank is used to store the water for feeding the water pump through nozzle.

Measuring tank is used to measure flow rate with using stop watch.

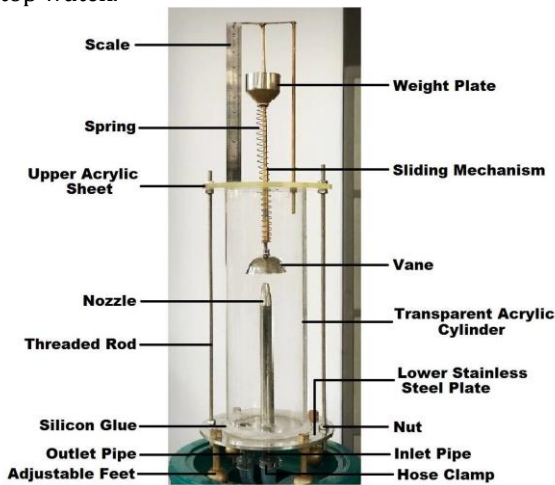

Fig.1 Impact of jet apparatus [3]

#### VI. EXPERIMENTAL PROCEDURE

- Note down the height between nozzle & the vanes (plate)
- Ensure that sufficient water in the sump tank
- Flow control valve open for small amount of water flow.
- Attach any one target plate to hanger system.
- Switch on the electric power supply and switch on the pump.
- Allow the water to flow to through the apparatus.
- Increase the flow of water by opening the flow control valve till the target plate lifted a little.
- Add the weight on the weight pan and increase the water flow till target plate gets lifted up.

- Note down measuring tank reading with respect to time using stopwatch note down the height of the target plate by using scale.
- Again add the weight on weight pan and increase the water flow till target plate get lifted.
- Each time we recorded the value of flow rate and weight on the weight cup and height above the disc.
- The above procedure was repeated again using different types of vanes.
- Switch of the pump and main switch.
- Close the flow control valve and water is drained from the tank.

#### VII. NOMENCLATURE

- $v$  = velocity of jet
- $d$  = diameter of jet
- $u$  = velocity of flat plate
- $A$  = area of x-section of the jet
- $\rho$  = density of water
- $Q$  = discharge of water
- $\dot{m}$  = mass flow rate
- $W$  = work done

#### VIII. CALCULATION

1) Momentum equation for fluids –

Net force experienced by fluid along x- direction

$F_N$  = Mass of water striking on plate per sec x [Initial velocity – Final velocity]

$$F_N = \dot{m} (V - u)$$

$\dot{m}$  = Discharge x Density

$$= \rho \times Q$$

According to equation of continuity equation,

$$\dot{m} = \rho \times A \times V \dots\dots (Q = A \times V)$$

$$\dot{m} = \rho \times A \times V \dots\dots \text{for stationary plate}$$

$$\dot{m} = \rho \times A \times (V - u) \dots\dots \text{for moving plate} \quad [6]$$

2) Force exerted by jet on the moving flat plate –

$$\dot{m} = \rho \times A \times (V - u) \dots\dots \text{for moving plate}$$

$F_x$  = Mass of water striking on plate per sec x [Initial velocity – Final velocity]

$$= \dot{m} \times (V - u)$$

$$= \rho \times A \times (V - u)$$

$$W = F_x \times u \quad [6]$$

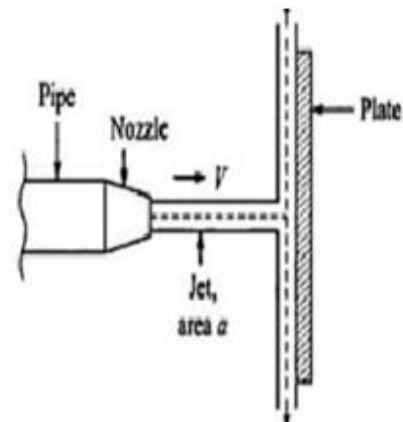

Fig.2 Flat plate [6]

3) Force exerted by jet on the moving inclined flat plate at an angle  $\theta$  -

$$\dot{m} = \rho \times A \times (V - u) \dots \text{for moving plate}$$

Force at normal to the plate -

$$F_N = \dot{m} [(V - u) \sin \theta - 0]$$

Force at x - direction -

$$F_x = \rho \times A \times (V - u)^2 \sin^2 \theta$$

Work done along the x - direction is

$$W_x = F_x \times u$$

Force at Y - direction -

$$F_y = \rho \times A \times (V - u)^2 \sin \theta \cos \theta$$

Work done along the Y - direction is

$$W_y = F_y \times u = 0$$

[6]

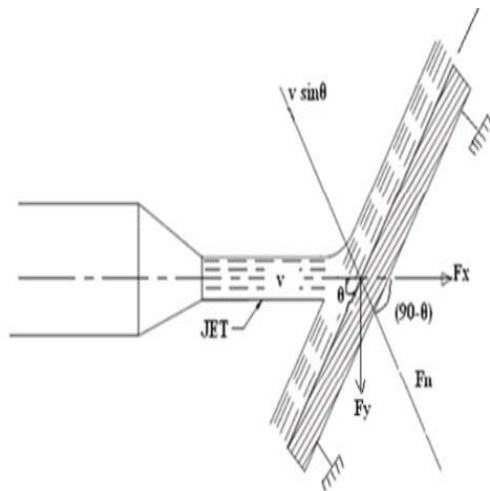

Fig.3 Inclined plate [6]

4) Force exerted by jet on the center of a moving hemispherical curved plate -

$$\dot{m} = \rho \times A \times (V - u) \dots \text{for moving plate}$$

$$F_N = \rho \times A \times (V - u)^2 [1 + \cos \theta]$$

Work done along the x - direction is

$$W_x = F_x \times u$$

[6]

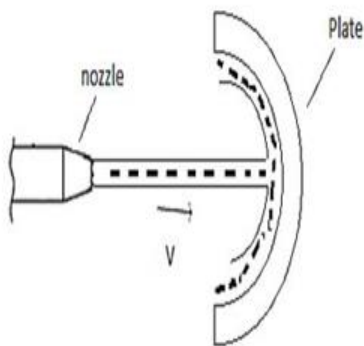

Fig.4 Hemispherical plate [6]

### CONCLUSION

Thus with these results we concluded that as the discharge increases the value of force exerted also increases, along

with that the accuracy of impact of test rig was increased and reduction in percentage of error was observed.

### ACKNOWLEDGMENT

We are thankful our faculty for their constant guidance and supervision regarding the project. We take this opportunity to express my gratitude toward our college Dr. D. Y. Patil College of Engineering and Innovation, Varale Campus, Talegaon.

### REFERENCES

1. Ankush kumar jain, (2017) "To verify the momentum equation by Impact of jet apparatus on flat plate", International Journal of Innovative and Emerging Research in Engg. vol.4.
2. N.M.Mali, Vijay, (2018) "Determination of force on flat and inclined plates using weighting pan in test rig of impact of jet", International Journal of Innovative and Emerging Research in Engg. vol. 5.
3. Farzad Hossain, (2018) "Measurement of flow rate and impact force on different vanes through impact of jet", International journal of modern research in Engineering and management paper, vol. 1.
4. Yusuf koc (2015) "An experimental study of mechanical effect in cleaning process", Sigma Journal Engineering and Natural Sciences
5. Aishwarya Singh Rathore (2018) "Role of vane angle and its shape on jet mixing of a subsonic coaxial jet", International journal of Engineering research in Cechemical and civil Engineering, vol. 3.
6. Dr. P. N. Modi (2011) "Hydraulics and fluid mechanics including hydraulics machines", Rajsons publications Pvt. Ltd. (PP 978,986)
7. Zueb Husain,(2008) "Basic Fluid Mechanics and . Hydraulic Machine" BS Publications Pvt. Ltd.(pp 25,26)