

DESIGN AND DEVELOPMENT OF FILAMENT MAKING DEVICE FOR 3D PRINTING MACHINE

VAIBHAV VIKRAM TARE

Student, Department of Mechanical Engineering, Dr. D.Y. Patil College of Engineering and Innovation,
Varale, Pune, M.S., India

AKASH MALLINATH GAVHANE

Student, Department of Mechanical Engineering, Dr. D.Y. Patil College of Engineering and Innovation,
Varale, Pune, M.S., India

KIRAN SOPAN AHER

Student, Department of Mechanical Engineering, Dr. D.Y. Patil College of Engineering and Innovation,
Varale, Pune, M.S., India

AJAY SURESH JADHAV

Student, Department of Mechanical Engineering, Dr. D.Y. Patil College of Engineering and Innovation,
Varale, Pune, M.S., India

PROF. SANKET S. CHIKSHE

Department of Mechanical Engineering, Dr. D.Y. Patil College of Engineering and Innovation, Varale,
Pune, M.S., India

ABSTRACT:

3D printing has made it possible to develop the prototypes for any upcoming product with accuracy and effective design. Generally plastic is used as a material for manufacturing the parts using 3D printers. The problem associated present machine is the cost of filaments and hence modifications are needed in the present machines in order to make the products better. We have designed a filament making machine with Polylactic Acid (PLA) and Acrylonitrile Butadiene and Styrene (ABS) as a material. These materials have good melting point. The modification in the present machine enables the making of filaments. It helps in cost saving for the small industries and workshops. Different diameters of the filaments can be produces with the design suggested by us. We have presented the CAD design and calculations of the design in this paper.

KEYWORDS: 3D Printing, plastic filament extruder, Die & Nozzle, ABS & PLA

INTRODUCTION:

In this paper we have presented the design of filament making machine. Our team done the design of machine and we are going to make the filament making machine as per the design objective. Input materials (Polymer) like Polylactic Acid (PLA) and Acrylonitrile Butadiene and Styrene (ABS) are used in the form of granules and pellets. Ceramics band heaters are used for melt the input materials. The melting point of PLA (180 0C) and ABS (105 0C) materials is controlled by using temperature controller and sensors.

Barrel screw are used for feed the input materials longitudinally along the screw. The screw has three zones feed zone, melt zone, metering zone. The filament quality is depending on the screw speed in relation with pressure and temperature ranges. Plastic filament extruder produces plastic filament of different diameters (1.75mm and 3mm) by using corresponding dies. For different diameters, different die are used but our team modified the existing convectional machine with changes as per the we can produce to different diameters filaments at a time using single stroke or single processing stroke of machine. The filament prices day-by-day increases. To overcome this problem faced by manufactures, small workshop owners, the filament making machine created. This project focus on the designing and fabricating a portable filament making machine with cheap to draw 1.75mm or 3mm diameter filament of PLA and ABS materials. The arrangement for plastic extraction is as shown below.

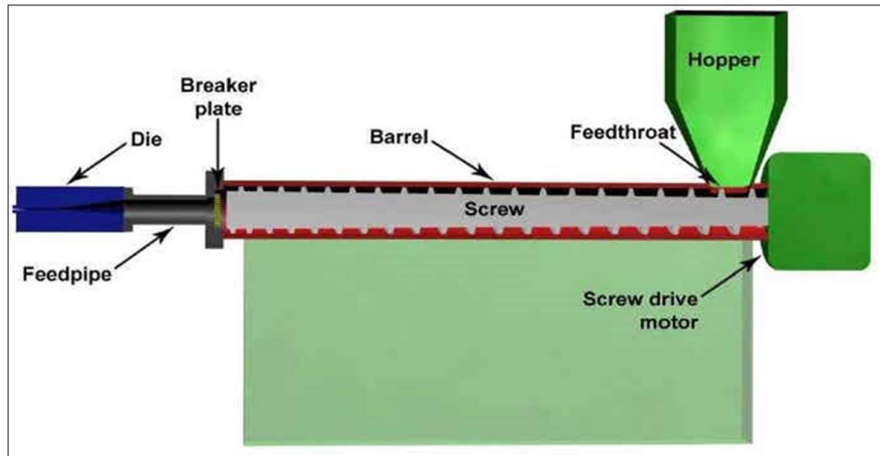

Fig. 1: Plastic Extrusion

OBJECTIVES OF WORK:

The objectives of the work are as follows,

- Designing and developing a plastic filament extruder for 3D printing
- The focus was specifically on creating 1.75 mm diameter filament from ABS pellets.
- Developing a 3D printing filament making extruder that can be used by small scale manufacturing units, companies, colleges who have portable 3D printer in-house.
- Doing design calculations to base the development of filament making extruder.

SYSTEM DESIGN:

Screw:

The diameter we decide to work with is 38 mm and for the relation between the length and the diameter we choose, 12/1. We are willing to work with optimum price hence consider 38 mm to be the smallest diameter with reasonable price and with precise usefulness. In addition, we choose 12/1 for the relation L/D because we consider 300 mm the maximum length keeping a light screw in terms of weight, taking into account that if the relation L/D is bigger, the price will be lower. Therefore, I have defined the first parameters of our screw D =38 and L=300.

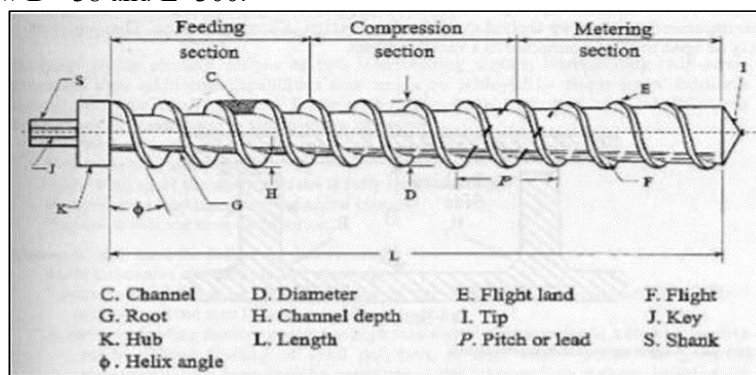

Fig.2: Screw Geometry Details

Helix Angle:

Also one of the first things we can determine of our extruder is the helix angle of the screw. For general purpose screws, the gap between 2 crests or the pitch (t) usually coincides with the diameter. So

t=D=15mm So the helix angle is

$$\phi = \tan^{-1} \frac{t}{\pi D} \dots\dots\dots$$

$$\phi = \tan^{-1} \frac{15}{\pi * 15}$$

$$\phi = 17.65$$

Ridge Width:

The width of the ridge is defined by the diameter of the screw as it exists a relation between them, $e=0.12*D$ So $e= .12*15$ $e = 1.8$ mm

Screw Lengths:

For amorphous thermoplastic, the feeding zone is between 20% and 25% of the screw length, the compression zone between 32% and 38% and for the metering zone between 40% and 45% . We based our decision of the zones lengths on the percentage from the total length that normally has each zone. The percentages used in each zone are obtained as follows:

$$\% = \frac{\%}{\%1 + \%2 + \%3}$$

$$L1\% = \frac{20}{20 + 32 + 40} = 0.217$$

$$L2\% = \frac{32}{20 + 32 + 40} = 0.348$$

$$L3\% = \frac{40}{20 + 32 + 40} = 0.435$$

Feeding Zone Length: $L1 = 0.217 * 300 = 65$ mm

Compression Zone Length: $L2 = 0.348 * 300 = 105$ mm

Metering Zone Length: $L3 = 0.435 * 300 = 130$ mm

Channel Depth and Screw Clearances:

The clearances inside the screw and with the cylinder are also defined by the diameter I have chosen. The channel depth $h1$ is the space between the cylinder and the soul of the screw. It is related with the screw diameter with the equation

$$h1 = 0.2 * D \quad h1 = 3 \text{ mm}$$

The filet clearance is the space between the thread and the interior surface of the cylinder. It should be small enough to avoid the plastic to come back while extruding.

The equation to calculate it is:

$$\delta = 0.002 * D \quad \delta = 0.03\text{mm}$$

The depth of the channel at the end of the screw is defined by the compression ratio (Z). The compression ratio relates the depth of the channel at the beginning and at the end of the screw.

Barrel or Cylinder:

Just as for the screw, the material chosen for the cylinder is steel F-174, for the same reasons. The cylinder must also be able to handle with high temperatures and be hard enough to resist degradation due to the friction generated between the inner face of the cylinder and the plastic flow. The cylinder is the part in charge of keeping the material inside while going throughout the screw. For this reason, its inner diameter is the sum of the screw diameter and the clearance calculated above, to a total of 25.05 mm. Considering tolerance and according to the availability of standard tube, 1" ID tube meets our requirement, so we have selected 1"ID tube for the cylinder.

Barrel Extension

Barrel Extension material is same as Barrel for the same reasons. It is manufactured by turning operation. It is welded to the end of the Barrel. This extension is used to couple barrel piece to die and to give sufficient thickness to fit the secondary heater. In addition, 4 mm thick aluminum strainer is attached to smoothen the flow and 3/8" nut to control the flow.

Hopper

Hopper is made up of stainless steel sheet metal. There are no specifications for hopper design. Volume for the rectangular section

$$V = L * B * H$$

$$V = 200 * 200 * 60$$

$$V = 2.4 * 10^6 \text{ mm}^3$$

$$\text{Volume of trapezoid} = \frac{1}{3} * (A1 + A2 + \sqrt{A1 * A2})h$$

$$= \frac{1}{3} * (12000 + 2400 + \sqrt{12000 * 2400}) * 60$$

$$= 395331.26 \text{ mm}^3$$

$$\text{Total Volume of Hopper} = 2795.331 * 10^3 \text{ mm}^3$$

Motor:

The motor for the system is a 30 RPM motor with stall torque of 30 Nm (100 N-cm). This motor is controlled by a PWM (Pulse Width Modulation) speed controller. This controller is wired in series with the power source from 12 V supply and the motor. This was the simplest control system. It is a variable speed control system with the RPM is selected by varying the duty cycle. Wiper motor operating at the 6.5A current & 12V power which has output rotating speed of 30 rpm with rated Torque of 13Nm



Fig.3: Wiper motor and 2SW60

Band Heaters:

Details: 6 mm (1/4") thick ceramic

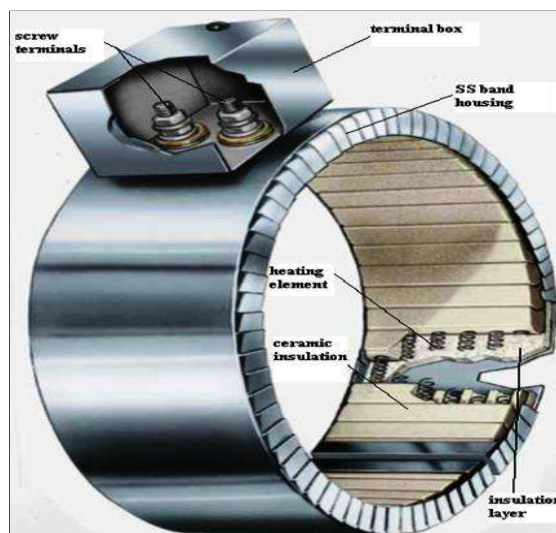

Fig.4: Ceramic Insulated Band Heater

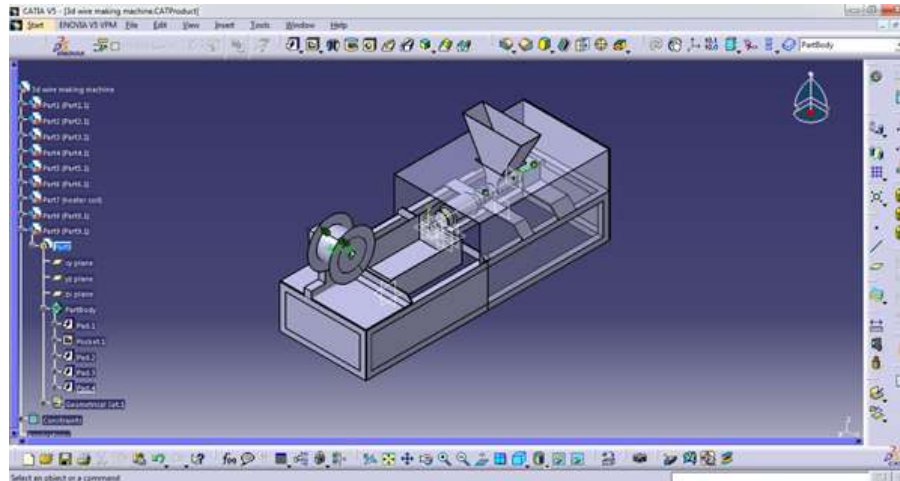

Fig.5: 3D Design of the Machine in CAD

CONCLUSION:

3D printing is future of manufacturing in coming time. The filament used in 3D printer is very important and its market price is increasing day by day with demand. Authors have presented a design of filament making machine for the 3D printer in this paper. The objective was to use Polylactic acid, Acrylonitrile Butadiene and Styrene as a material for filaments. These materials have melting point below 200 degrees and hence it can be controlled by using temperature control. This machine will be useful for the small industries with cost effectiveness. The machine is designed to produce the filament of 1.75 mm diameter.

REFERENCES:

- 1) Ware, William E. "Control of plastic extruders with multiple temperature zones using a microprocessor based programmable controller system." IEEE transactions on industry applications 4 (1984): 912-917
- 2) Saad, Mohd Sazli, Hishamuddin Jamaluddin, and Intan Zaurah Mat Darus. "Implementation of PID controller tuning using differential evolution and genetic algorithms." International Journal of Innovative Computing, Information and Control 8.11 (2012): 7761-7779.
- 3) Dong, Hwa Kim, Pyo Hong Won, and Hack Lee Seung. "Intelligent Tuning of the Two Degrees-of-Freedom Proportional-Integral-Derivative Controller On the Distributed Control System for Steam Temperature Control of Thermal Power Plant." KIEE International Transaction on Systems and Control 2.2 (2002): 78-91.
- 4) Ravi, S., and P. A. Balakrishnan. "Stable self-tuning genetic fuzzy temperature controller for plastic extrusion system." International Journal of Reviews in Computing 5.4 (2011): 21-28.
- 5) Seema Are, Pooja Khatri and Jatin Garg, "Proportional Integral Derivative controller Tuning Of Temperature Control system", International journal of electronics, Information and systems, Vol.12, No.2,pp.37-42,2010.
- 6) A.K.Kochar "Dynamic Modelling and control of plastic extrusion processes", *Automatica*,vol.13, N0.2,pp.177-183,1977.